

WASTEWATER PURIFICATION IN HUNGARY

USING NATURAL ZEOLITES

DÉNES KALLÓ

Central Research Institute for Chemistry
 Hungarian Academy of Sciences
 P. O. Box 17
 H-1525 Budapest, Hungary

ABSTRACT

Clinoptilolite-rich tuffs (Tokaj Hills, Hungary) have been utilized in two stages of treatment of municipal wastewater. The addition of 30-100 g of powdered tuff of 40-160 μm grain size to 1 m^3 of raw sewage before the aeration tank was found to (1) increase the oxygen consumption rate, i.e., the biological activity of the living sludge by a minimum of 25%, (2) cause an increase in sedimentation rate because the content of suspended solids in the effluent after the secondary settling tank decreased, e.g., from 35 to 18 mg/liter or from 10 to 4 mg/liter, and (3) decrease the mole ratio of added $\text{Fe}^{3\pm}$ or $\text{Al}^{3\pm}$ salts to phosphate from 2.0-2.5 to 1.2-1.8, i.e., similar amounts of phosphate were removed using less of an excess of these salts. The resulting sludge was more easily dewatered and could be used as a fertilizer. Its anaerobic digestion required 20—24 days instead of 30—35 days. Heavy metals bound to the clinoptilolite in the sludge were more slowly released by orders of magnitude than from normal sludge.

Ammonium from treated effluent was removed in an ion-exchanger bed filled with 0.5-2 mm granules of the zeolitic tuff. From alkaline regenerating solutions of KCl/NaCl, ammonia was removed by stripping and absorbed in phosphoric acid. Ammonium hydrophosphate was thus produced and used as a fertilizer.

In addition to its favorable ion—exchange properties, the texture of the rock played an important role in this technology by providing a broad distribution of pore spaces, which allowed easy access to the embedded zeolite crystals thereby permitting sorption of large particles, such as bacteria, and by serving as a reservoir for salt solutions.

INTRODUCTION

The improvement of sewage—treatment technologies is of both ecological and economical importance to obtain increased removal of ammonium, phosphorus, and organic floating material (suspended solids). Chemical methods have usually been applied. Suspended solids are flocculated by adding aluminum salts or synthetic polyelectrolytes (Hahn ET *al.*, 1978); phosphorus is precipitated as phosphate with aluminum or iron salts or with lime (Bernhardt, 1975; Goldshmid, 1978); and ammonium is generally removed by biological nitrification. Similarly, organic

contaminants are biologically oxidized (van Haandel *et al.*, 1982). The problem of the disposal of the sludge that is produced has not been satisfactorily solved, mainly because of accumulated heavy metals, which are easily released from it into the soil. In addition, the above-mentioned chemicals are rather expensive and often result in undesired emissions.

The use of relatively low-priced natural zeolites as ion-exchangers and/or adsorbents has been found to be promising (see, e.g.,

Sand and Mumpton, 1978). Among them, clinoptilolite occurring in large deposits (e.g., Hay, 1966) has a large selectivity for NH_4^+ (Ames, 1960), heavy metal cations, e.g., Pb^{2+} , Cd^{2+} , Zn^{2+} , Cu^{2+} (e.g., Assenov *et al.*, 1988), and Cs^+ and Sr^{2+} (see, e.g., Nikashina and Zaborskaya, 1977). Clinoptilolite-containing rhyolite tuffs comprise pores ranging from 10 to 1000 μm in diameter (e.g., Mihalyi and Kallo, 1985) that allow access to the embedded zeolite crystals and enable large particles, such as organic molecules and even bacteria to be sorbed. Adsorption of organic contaminants and nutrients is enhanced by the polar character of the surface of impurity mineral constituents of the tuff, such as quartz, cristobalite, monrrnorillonite, feldspar, and volcanic glass. Clinoptilolite-rich tuff from Tokaj Hills, eastern Hungary, has these required properties (Kallo *et al.*, 1982).

In the present investigation the clinoptilolite-rich tuff from Tokaj Hills was applied in two stages of municipal sewage treatment: (1) in the biological treatment stage, in which an increase of biological activity (i.e., the oxygen consumption rate by the living sludge) was sought, based on the adherence of bacteria-flocs to small clinoptilolite rock grains (a few tens of micrometers), resulting in an increase in the settling rate, and (2) in the removal of residual ammonium from the biologically treated and settled sewage as a result of cation-exchange in a column filled with millimeter-size grains of the clinoptilolite-rich tuff.

Main features of the suggested technology have been disclosed in the patent description of the ZEOFLOCC process (Kiss *et al.*, 1988). Results of above application and supplementary investigations in connection with sludge utilization are reported here.

EXPERIMENTAL

Materials

A clinoptilolite-rich rhyolite tuft from Mad, Tokaj Hills, Hungary was used in this study. The mineralogical composition, as determined by X-ray diffraction analysis of homoionic samples was: 50-60% clinoptilolite, 510% quartz-cristobalite, 5-10% feldspar, and 20-40% volcanic glass. Its bulk chemical composition (wt. %) after ignition at 900°C was: SiO_2 69.50; Al_2O_3 , 11.65; Fe_2O_3 , 1.06; Na_2O , 0.44; K_2O , 4.44; MgO , 0.59; CaO , 1.83; LOI, 10.53. The clinoptilolite itself contained neither sodium nor magnesium as determined by scanning electron microscopy coupled with energy dispersive X-ray analysis (SEM-EDAX) (Miklosy *et al.*, 1983). Its overall cation-exchange capacity ranged between 1.0 and 1.2 meq/l/g (Kallo *et al.*, 1982). The surface area of the zeolitic tuff (referred to in the following as "clinoptilolite ") was $30 \text{ m}^2/\text{g}$ by toluene adsorption (Detrekdy *et al.*, 1974). The porosity determined with mercury porosimeter (Carlo Erba 2000) was: pore radius $<32 \text{ \AA}$, 0.1; pore radius $32-200 \text{ \AA}$, 0.1; pore radius $200-75,000 \text{ \AA}$, $0.2 \text{ cm}^3/\text{g}$.

Grains of clinoptilolite (40–160 μm size range) were suspended in an aqueous solution of FeClSO_4 containing 200 g Fe^{3+} /liter (Borsod Chemical Works, Hungary, trade name Ongrofloc, $d = 1.52 \text{ g/cm}^3$). Suspensions containing different clinoptilolite/iron ratios were prepared and added to the sewage in the biological treatment step. In some experiments $\text{Al}_2(\text{SO}_4)_3 \cdot 18\text{H}_2\text{O}$ of technical purity was used as a flocculent in the biological treatment. NH_4 exchanger columns were filled with the clinoptilolite-rich tuft of 0.52.0 mm grain size.

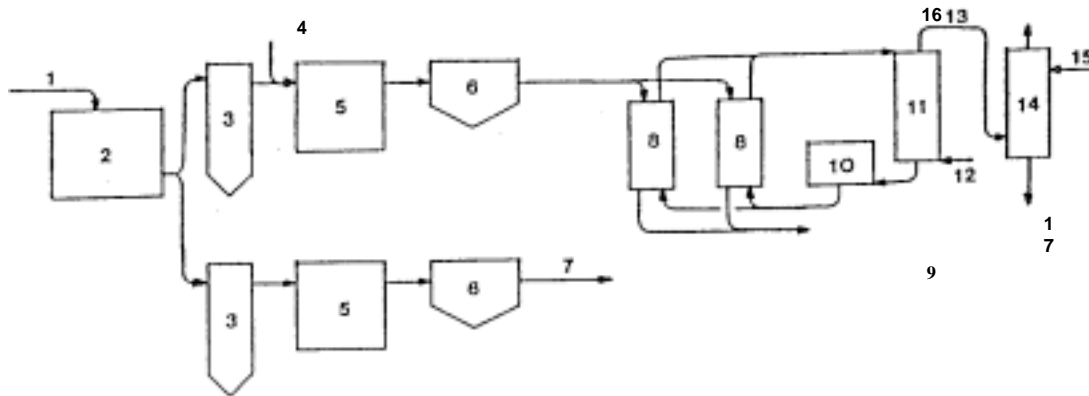

Figure 1. Flow diagram of pilot plant for sewage treatment with clinoptilolite. 1. raw sewage; 2. buffer tank; 3. primary settling tanks; 4. clinoptilolite (+ FeClSO₄); 5. aerators. 6. secondary settling tanks; 7. effluent, control line; 8: ion-exchangers; 9. effluent, test line; 10. regenerating solution; 11. stripper; 12. air; 13. NH₃air; 14. absorber; 15. H₃PO₄; 16. air; 17. NH₄H₂PO₄ precipitate.

Methods

Steady-state experiments were carried out in a pilot plant (50 m³/day, Figure 1), and in working plants (100, 400, 2,000, and 20,000 m³/day). The treatment plants used the same technological line: screen, grit chamber, primary settling tank, aerator, secondary settling tank. In addition to these installations, the pilot plant was equipped with an ammonium ion-exchanger and regeneration unit (Figure 1).

The clinoptilolite suspension was added to the sewage before it entered the aerator. Most of the working plants consisted also of two identical parallel lines: one for testing the effects of clinoptilolite additive, and one for control without any additive.

Chemical oxygen demand (COD), biological oxygen demand for a standard five-day period (BOD₅), total phosphorus, orthophosphate, NH₄⁺, and NO₃⁻ contents, and the amounts of suspended solids were monitored daily in the inlet sewage and in the effluents downstream of the secondary settling tanks. The Mohlmann index (a measure for sludge sedimentation characterizing the dewaterability

of removed excess sludge) was determined and the sludge stabilization was studied (Graef and Andrews, 1974; Hartmann *et al.*, 1979).

NH₄-exchange experiments were carried out in the laboratory using columns of 40 cm³ and 170 cm³ and in the pilot plant (column volume = 1 m³). Ammonium was exchanged from a solution of distilled water and NH₄Cl in the laboratory and from biologically treated sewage in the pilot plant in a down-flow direction. Regeneration with KCl, and/or NaCl/KCl solutions of different pH established with lime addition was carried out in an up-flow mode using fresh solutions or recycled solution, which enabled the volume of regenerating solution to be reduced. Stripping of ammonia from the regenerating solution at pH = 9-10 was performed with air at ambient temperature.

RESULTS

Biological treatment

The results of experiments in different-capacity sewage-treatment plants are summarized

Table 1. Mean composition (mg/liter) of sewage in biological treatment plants for a 2-week period after establishment of steady-state conditions.

Capacity (m ³ /d)	Sewage ¹	Added ²						Susp.	
		Cp	Fe ³⁺	COD ₃	BOD ₅ ⁴	NH ₄ ⁻	NO ₃ ⁻	PO ₄ ³⁻	solids
43	Inlet			161	89	32.5	1.6	4.0	88
	Contr.	-	-	69	16	28.6	16	3.0	27
	Test	65	17.5	44	9	10.0	30	0.4	15
100	Inlet			306	155	321	0.7	5.4	144
	Contr.	-	-	54	13	20.3	24	3.8	17
	Test	3	23.2	36	8	1.0	57	0.5	9
400	Inlet			83	32	22.3	2.3	2.9	22
	Contr.	-	-	37	8	0.8	53	2.2	10
	Test	35	16.0	28	5	0.6	85	1.0	5
1850	Inlet			411	194	41.1	0.6	5.5	69
	Contr.	-	-	68	19	6.4	28.2	3.6	35
	Test	44	20.9	63	18	2.8	42.1	0.9	18

¹Inlet = raw sewage inlet to aerator; Contr. = sewage treated without additive after primary settling tank; Test = sewage treated with additive after primary settling tank.

²mg/liter; Cp = clinoptilolite-rich tuff.

³Chemical oxygen demand.

⁴Biological oxygen demand.

in Table 1. The sludge concentrations were about 5 kg/in³ in all experiments. The addition of clinoptilolite increased the biological activity of the sludge as shown by the increased oxygen uptake. In the pilot plant (43 m³/day loading), the rates of oxygen uptake (in mg oxygen/g/hr) were 52 without and 65 with clinoptilolite addition; for the 100 m³/day plant these values were 35 and 44, respectively. The rate increase of 25% was due to the clinoptilolite addition. The addition of flocculating Fe³⁺ or Al³⁺ salts without clinoptilolite in a dosage of 0.4 mmole/liter increased this rate by less than 10%.

A comparison of the enhancement of biological activity by different additives indicates that the introduction of 50 mg

synthetic zeolites A or X, perlite, charcoal, and clinoptilolite in 1 liter of sewage with sludge gave rates of oxygen consumption of 4, 7, 32, and 77 mg/liter/hr, respectively.

The rate of nitrification was nearly twice that found for treatments without clinoptilolite. The addition of iron salt alone increased the nitrification rate by only 20-25%.

The addition of clinoptilolite decreased the Mohlmann indices from 140-210 cm³/g to 50-100 cm³/g. For clinoptilolite-containing sludge, the time needed for stabilization was 25 days. The COD values of water removed during composting was 705-850 mg/liter, and the ammonium content was 560 mg/liter.

These values for normal sludge are 35 days to obtain stabilization, 1250 mg COD/liter, and 870 NH_4^+ mg/liter. The phosphorus content of effluent was decreased to less than the level permitted by Hungarian regulations, i.e., < 1.8 mg P/liter at an iron/phosphorus ratio of 1.2-1.8 in the presence of clinoptilolite; this ratio was 2.0-2.5, without the zeolite. The addition of 50 mg clinoptilolite/liter removed <0.5 mg P/liter (as PO_4^{3-}).

The range of COD values and total phosphorus are illustrated in Figures 2 and 3, respectively, for aluminum sulfate and clinoptilolite/ Fe^{3+} additives. The mean COD value of the effluent was 10 mg/liter less for clinoptilolite/ Fe^{3+} than for aluminum sulfate additive. The ratio of Fe^{3+}/P ranged between 1.0 and 2.1, whereas the Al^{3+}/P ratio was unchanged at 3.2, i.e., more aluminum had to be introduced than iron with the clinoptilolite to attain a similar level of phosphorus removal. If the concentration of phosphorus abruptly increased in the raw sewage and the steady-state concentration of clinoptilolite had already been established in the system (after 14 days), the concentration peaks of phosphorus were significantly smaller in the effluent than in the parallel experiment using aluminum sulfate additive. If the addition of clinoptilolite-Ongrofloc mixture was stopped, the phosphorus content in the effluent started to increase two days later. If, however, aluminum sulfate additions were stopped (or sole dosage of iron salt), a similar increase was observed within 12 hr (not shown in Figure 3).

In a large-scale plant of 20,000 m^3/day capacity (not listed in Table 1), the quality of the effluent was improved by adding 75 mg clinoptilolite suspended in 160 mg Ongrofloc (Fe^{3+} content = 21 mg) to 1 liter sewage: the COD of the effluent decreased from 110-130 to 45-60 mg/liter; BOD_5 , from 10 to 5 mg/liter; and NH_4^+ , from 8 to 3 mg/liter.

Ammonium removed by ion exchange

After biological treatment, residual ammonium was removed by ion exchange with clinoptilolite. Dynamic ion-exchange capacities were determined to a breakthrough value of 4 mg NH_4^+ /liter (Table 2). Exhausted beds were regenerated with KCl solution at a flow rate of 2 BV/hr (BV bed volume). About 90% regeneration was attained by passing 6, 7, and 16 BV of solutions containing 100, 20, and 5 g KCl/liter, respectively. To reduce the volume of regenerating solution, the regenerations were carried out by recycling the regenerating solution. During recycling, the concentration of ammonium in solution increased steadily. Table 3 shows that the increase of ammonium concentration in the regenerating solution reduced the efficiency of regeneration, i.e., the degree of ion-exchange for K^+ cations was reduced. At higher pH, the regeneration was less inhibited by ammonium than in neutral solution.

Similar breakthrough experiments were carried out in the pilot plant (Figure 1) with biologically treated sewage (Figure 4, Table 4). Regeneration was carried out using a solution containing 26 g NaCl/liter, 14 g KCl/liter, and Na_2CO_3 to establish a pH value of 9-10. A 90% regeneration was attained by 20-22 BV of regenerating solution; the cumulated regenerating solution contained 250 mg NH_4^+ /liter.

Ammonia was stripped by air in a column (Figure 1) filled with Raschig rings, while pH decreased to 7.5-8. The pH was readjusted to 10 by adding KOH/NaOH, which supplied, by the addition of KCl/NaCl, alkaline cations for subsequent regeneration of the ion-exchanger. Evolved ammonia was absorbed in H_3PO_4 , and ammonium hydrophosphate solution was produced.

Table 2. Effect of grain size, flow rate, and solution concentration on ammonium ion exchange capacity of clinoptilolite-rich rhyolitic tuff from Tokaj, Hungary.

Bed volume BV (cm ³)	Grain size (mm)	Flow rate (BV/hr)	NH ₄ ⁺ conc. (mg/liter)	Break-through (BV)	NI-I ₄ + exchange (mg NH ₄ ⁺ /g)	(meq/g)
40	0.5-1.0	10	50	73	4.36	0.240
40	1.0-1.6	10	50	29	1.71	0.095
40	0.5-1.0	15	100	30	3.22	0.179
40	0.5-1.0	15	50	70	4.15	0.230
40	0.5-1.0	15	30	166	5.57	0.309
170	0.5-1.0	10	50	68	4.06	0.225

*Breakthrough volume required to achieve 4 mg NH₄⁺/liter concentration.

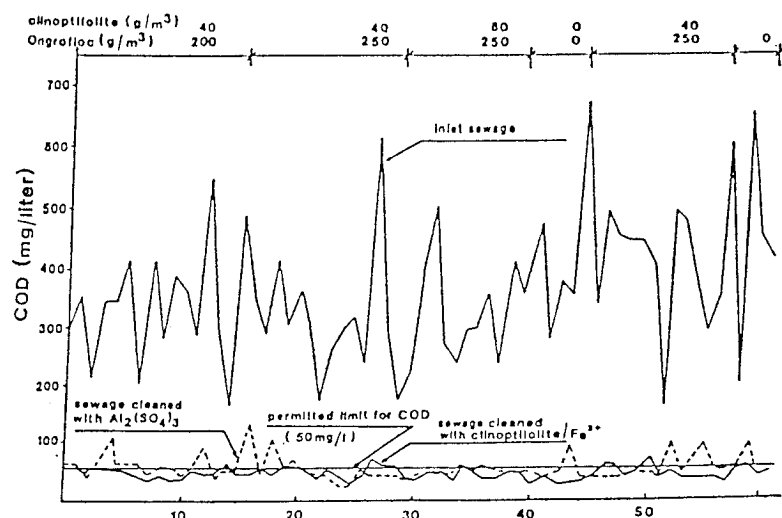
Figure 2. Changes of chemical oxygen demand (COD) in inlet sewage, in aluminum salt—treated effluent, and in clinoptilolite ± Fe³⁺ treated effluents (plant capacity = 2000 m³/day).

DISCUSSION

The addition of about 50 mg powdered clinoptilolite-rich tuff to 1 liter of sewage increased the efficiency of biological treat-

ment by 30-50%. Zeolite grains appeared as substrates for bacteria flocs. The flocs of bacteria bound to the grains were more efficient than normal flocs in sludge, because:
(1) NH₄⁺ nutrient was enriched on the sur-

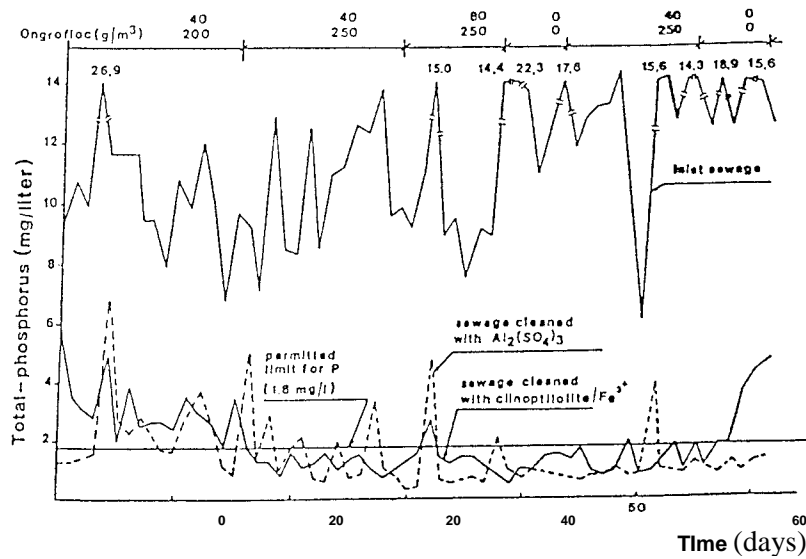

Figure 3. Phosphorus concentration in inlet sewage, in aluminum salt— treated effluent, and in clinoptilolite + Fe³⁺-treated effluent (plant capacity ~2000 m³/day).

Table 3. Effect of ammonium content on efficiency of regeneration (40 bed volume regenerating solution passed through exhausted ion-exchange column).

Concentration	NH ₄ ⁺ concentra- tion (mg/liter)	Regeneration efficiency (%)	
20g KCl/liter	150	92	
pHz+7	200	89	
	500	80	
	2000	93	
74.5 g KCl/liter	4000	91	
12 g KOH/liter	6000	88	
	pH = 11-12		

face of the zeolite, and (2) the small and uniform particle size resulted in enhanced mass transfer between the bacteria and aerated wastewater. With zeolites the flocs were smaller than 0.3 mm, whereas without zeolites, the size of floes was 0.4 and 2 mm.

In the slightly alkaline sewage, iron and

aluminum salts were converted to precipitates, which in turn promoted flocculation. The floc formation induced in this way was much less efficient than in the presence of zeolite-containing grains. The clinoptilolite-rich rock particles provided additional properties, such as polarity, ion-exchange ability, and a rigid pore structure of appropriate size. The sedimentation rate of suspended solids increased by 100%, because flocs attached to 'heavy clinoptilolite particles settled faster than normal flocs.

The zeolite-containing sludge was more easily dewatered than normal sludges. This phenomenon is attributed to the structure of the sludges. Probably, the insoluble organic material consisting mainly of bacteria adhered to zeolite grains and formed a less continuous network in aqueous medium than in the absence of zeolite; suspensions encapsulate water more weakly than gels. Clinoptilolite promoted composting of the sludge.

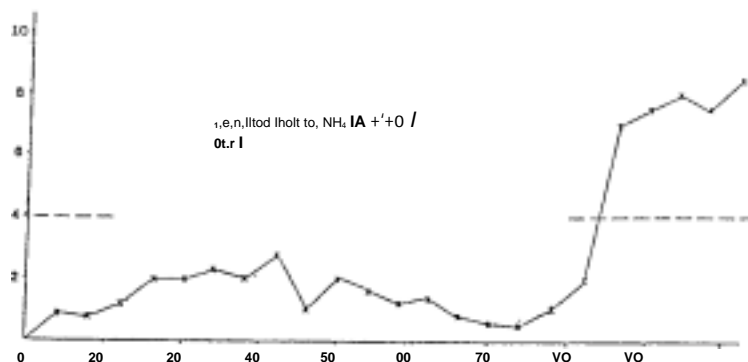

Figure 4. Ammonium, breakthrough curve for sewage feed containing 40 mg NH₄₊/liter in a column filled with I in³ (850 kg) clinoptilolite—rich tuff.

Table 4. Pilot plant data for ammonium ion—exchange (conditions: grain size 0.5—2.0 mm; BV = 1 in³ flow rate = 1.8—2.0 BV/hr).

Duration of breakthrough (Pr)	NH ₄₊ conc. in feed (mg/liter)	Breakthrough (DV)	Breakthrough	NH ₄₊ ion-exchange (mg NH ₄₊ /g)
48	39	286	+0.4	+0.10 ±+3.91 ++3.56
30	43-17	260	2	
30	25	not obs.		1.00
1192	8.2	+150		

¹Grain size = 0.5-1.0 mm; BV = 0.3 In³ flow rate = 8 BV/hr.
²Break—through concentration 4 mg NH₄₊/liter. ³Break—through concentration 3 mg NH₄₊/liter. ⁴Ammonium content of clinoptilolite after regeneration.
⁵Increase of ammonium content after ion-exchange.

The role of clinoptilolite in this process is not exactly known yet.

To decrease a phosphate concentration of 15-20 mg P/liter to <1.5 mg P/liter in the sewage, a 2-2.5-fold excess of Fe³⁺ ions had to be used relative to the amount of the PO₄³⁻ ions; with the introduction of clinoptilolite, the Fe³⁺/P ratio was reduced to 1.2-1.8. A similar reduction was also attained with the addition of Al³⁺ (data not shown). The retarded release of Fe³⁺ and Al³⁺ by the added clinoptilolite is probably

responsible for the greater efficiency of these metal ions for phosphate removal. The retarded release also explains the buffering capacity of the system: (1) high peaks in phosphate loading were not noted in the effluent; and (2) if the dosage of iron (or aluminum) salt were stopped, phosphate removal was unchanged even for two days, whereas, without clinoptilolite, phosphate removal was maintained for <12 hr.

Residual ammonium was removed from

the biologically treated sewage by ion-exchange on clinoptilolite. In practice, if the utilization of the ammonium is intended, nitrification should be kept at low level during the biological treatment in order to preserve large amounts of ammonium in water. Under dynamic conditions, about 20% of the static ion-exchange capacity was exhausted before the desired concentration of 4 mg/liter in the effluent was reached. For a grain size of 0.5-1.6 mm, ion-exchange was controlled by diffusion, because the rate of ion-exchange increased by decreasing grain size. The column was regenerated with KCl and/or NaCl solutions. With increasing concentration of NH_4^+ in the solution, the efficiency of regeneration decreased; however, increasing the pH to 10 by adding KOH and/or NaOH to the solution resulted in 90% regeneration at 2000-6000 mg NH_4^+ /liter concentration. Near this high pH, NH_3 , can be stripped with air, if air is blown in the bottom of a column filled with Raschig rings and the regenerating solution flows downward.

By absorbing NH_3 in phosphoric acid, a high-quality ammonium hydrophosphate fertilizer can be produced. After evolution of NH_3 , the pH of the regenerating solution was increased by addition of KOH/NaOH. Alkali metal ions introduced into clinoptilolite during regeneration were removed again by NH_4^+ in the new cycle of operation.

Preliminary results (to be published elsewhere) suggest that the composted sludge may be a useful fertilizer. The clinoptilolite-containing composted sludge increased the yield of vegetables (e.g., onions, spinach, tomatoes, beans) without phytotoxic effects and without heavy metal accumulation in the plants in excess of that permitted for human consumption.

SUMMARY AND CONCLUSIONS

The addition of 40—80 mg clinoptilolite—containing tuff, having a grain size of 40-160 μm , to 1 liter of municipal wastewater, before

the biological treatment, resulted in:

- (1) 30-50% increase in the biological activity of the living sludge, i.e., the capacity of the aerator;
- (2) 50-100% increase in the settling rate of suspended solids;
- (3) easier dewatering and composting of the produced sludge, compared with the normal sludge; and
- (4) reduction in the amount of excess simultaneously added Fe^{3+} (or Al^{3+}) salt for phosphate removal from 2-2.5 to 1.2-1.8-fold.

Ammonium was removed from biologically treated sewage by ion-exchange in a column filled with the clinoptilolite-containing tuff (grain size 0.5-2 mm). The clinoptilolite was regenerated using an alkaline solution of KCl/NaCl. Ammonia was then stripped from the regenerating solution with air and absorbed in phosphoric acid; hence, the ammonia removed from the sewage was used to produce an ammonium hydrophosphate fertilizer.

ACKNOWLEDGMENTS

I am grateful to my co-worker J. Papp and to engineers Gy. Mucsy and J. Olah for the experiments in the sewage-treatment plants. The research was financially supported by the National Scientific Research Foundation (OTHA, contract No. 1007), National Committee for Technological Development, Hungary (contract No. 7-16-0398), and by Water Construction Trust, Budapest.

REFERENCES CITED

- Ames, L. L. (1960) The cation sieve properties of

- clinoptilolite: *Amer. Mineral.* 45, 689—700.
- Assenov, A., Vessilev, Cli., and Kostova, M. (1988) Simultaneous sorption of metal ions on natural zeolite clinoptilolite: in *Occurrence, Properties and Utilization of Natural Zeolites*, D. Kallo and H. M. Sherry, eds., Akademiai Kiado, Budapest, 471-480.
- Bemhardt, H. (1975) Phosphor- und Stickstoffeliminierung im technischen Massstab: in *Gewasserschutz, Wasser, Abwasser Ser., Vol. 17*, B. Bdlinke, ed., Inst. Siedlungswasserwirtschaft Techn. Hochschule Aachen, Aachen, Germany, 1-58.
- Detrokoy, E. J., Jacobs, P. A., Kallo, D., and Uytterhoeven, J. B. (1974) The nature and catalytic activity of hydroxyl groups in clinoptilolite: *J. Catal.* 32, 442-451.
- Gerber, A., Mostret, E. S., Winter, C. T., and De Villers, R. H. (1987) Interaction between phosphate, nitrate and organic substrate in biological nutrient removal process: *Water Sd. Technol.* 19, 183-194.
- Goldschmid, T. (1978) Aqueous chemistry and precipitation of aluminum phosphate: in *Chemistry of Wastewater Technology*, A. J. Rubin, ed., Ann Arbor Science Publ., Ann Arbor, Michigan, 59-86.
- Graef, S. P. and Andrews, J. F. (1974) Stability and control of anaerobic digestion: *J. Water Poll. Control Fed.* 46, 666-683.
- Hahn, H. H., Eppler, B., and Klute, R. (1978) Comparison of wastewater flocculation in jar test experiments, continuous flow reactor, and large scale plants: in *Chemistry of Wastewater Technology*, A. J. Rubin, ed., Ann Arbor Science Publ., Ann Arbor, Michigan, 245-262.
- Hartmann, R. B., Smith, D. G., Benett, B. R., and Linstedt, K. D. (1979) Sludge stabilization through aerobic digestion: *J. Water Poll. Control. Fed.* 51, 2352-2365.
- Hay, R. L. (1966) Zeolites and zeolitic reactions in sedimentary rocks: *Geol. Soc. Amer. Spec. Pap.* 85, 130 pp.
- Kallo, D., Papp, J., and Valyon, J. (1982) Adsorption and catalytic properties of sedimentary clinoptilolite and mordenite from Tokaj Hills, Hungary: *Zeolites* 2,13-16.
- Kiss, J., Hosszu, A., Deak, B., Kallo, D., Papp, J., Meszarosne-Kis, A., Mucsy, Gy., and Olah, J. (1988) Process and equipment for removal of suspended material, biogenetic nutrients and dissolved metal compounds from sewage contaminated with organic and/or inorganic substances: *Eur. Patent* 0 177,543, 11 pp.
- Kiss, J., Hosszu, A., Deak, B., Kallo, D., Papp, J., Meszarosne-Kis, A., Mucsy, Gy., and Olah, J. (1988) Process for preparing an agricultural fertilizer from sewage: *U.S. Patent* 4,772,307, 8 pp.
- Mihalyi, R. NI. and Kallo, D. (1985) Reaction conditions and active sites for I —butene hydration on zeolite and ion—exchange resin catalysis: *Acta Chim. Hung.* 118, 33 1-340.
- Miklosy, E., Papp, J., and Kallo, D. (1983) Xylene isomerization on H-mordenites and H-clinoptilolites: *Zeolites* 3,139-148.
- Nikashina, V. A. and Zaborskaya, B. Yu. (1977) Equilibrium and kinetic characteristics of the clinoptilolite in the selective extraction of ions from aqueous solution: in *Proc. Symp. Clinoptilolite, Tbilisi, 1974*, G. V. Tsitsishvili, T. G. Andromtikashvili, and A. Yu. Krupennikova, eds., Mescnierebe, Thilisi, 109-112.
- Sand, L. B. and Munipton, F. A., eds. (1978) *Natural Zeolites: Occurrence, Properties, Use*, Pergamon Press, Elinsford, New York, 546 pp.
- Van Haandel, A. C., Dold, P. L., and Marais, G. v. R. (1982) Optimization of nitrogen removal in single sludge activated sludge process: *Water Sci. Technol.* 14, 443-461.